



# Design Of Web-Based Library Information System With Framework For The Application System Thinking (FAST) Method

Rian Agum Gumelar<sup>1</sup>

<sup>1</sup> Faculty of Social and Science, University of Pembangunan Panca Budi, Indonesia

---

## Article Info

### Article history:

Received Sep 19, 2023

Revised Sep 20, 2023

Accepted Sep 22, 2023

---

### Keywords:

Information System

Library Website

FAST Method

---

## ABSTRACT

To develop interest in reading in school students, schools and libraries must work together to attract students' interest in reading. One of them is by providing a library at the school. Currently, many school libraries for management are still manual, such as from recording member data, data bookkeeping to storing other data related to transaction processing to report generation, so it is possible that when the process takes place there are errors in recording, lack of accurate reports made and delays in finding the required data. In addition, the library has operating hours so that few students come. Designing a web-based library information system with a fast method is the best solution to solve the problems that exist in this library. Fast methods make system design easier and more targeted. And the existence of a site-based Library Information System increases students' reading interest because they can access it anywhere and anytime without being limited in time, and also makes it easier for officers to Manage Library data.

*This is an open access article under the [CC BY-NC](https://creativecommons.org/licenses/by-nc/4.0/) license.*



---

## Corresponding Author:

Rian Agum Gumelar,  
Faculty of Social and Science,  
University of Pembangunan Panca Budi,  
Indonesia,  
Email: [ryangumelar55@gmail.com](mailto:ryangumelar55@gmail.com)

---

## 1. INTRODUCTION

The main problem faced by the Indonesian people, especially in the field of education, in the era of globalization is the low level of quality of human resources. One of the efforts to improve the quality of human resources is the development of reading interest and reading habits (Herny & Zuliarso, 2012). In 2011, UNESCO released the results of a reading culture survey of residents in ASEAN countries. Reading culture in Indonesia is in the lowest rank with a value of 0.001. That is, out of about a thousand Indonesians, only one has a high reading culture. (Triatma, 2016).

According to the Founder of the Indonesian Library Development Foundation, Trini Hayati, one of the causes of children's low interest in reading is the difficulty of accessing books. Even a high reading spirit becomes meaningless without a book that can be read. (Amiranti, 2017). In addition, the low interest in reading is caused by several things, including the high price of books and limited library

facilities, which causes reading to no longer serve as a means of learning and entertainment for the people of Indonesia. (Triatma, 2016).

Libraries are part of learning resources that must be owned by every school, college. Because students easily find information or knowledge through the library. The library is a unified work unit consisting of several parts, namely, the collection development section, the collection processing section, the user service section, and the facilities and infrastructure maintenance section. (Hutagalung & Arif, 2018).

Libraries at State Junior High School 7 Bekasi are currently managed manually, starting from the list of members, book data, member data, the process of borrowing and returning books, as well as making library reports, this causes library managers to process library reports manually, namely by using a ledger that makes these activities ineffective and inefficient. The system of borrowing and returning books in libraries that still uses a manual system is feared that there will be errors when recording book borrowing, the number of books available, difficulties when searching for books and what book information is available (Maryono & Darwati, 2017).

The advantages of a website-based library system include: members can find out the availability of books to be borrowed; assist librarian in managing library data and making reports; the reporting process is getting better, because it can be accessed and printed directly. (Dari, Sari, & Astrilyana, 2019).

The purpose of this research is to design a web-based school library information system that can provide information for visitors and make it easier for officers to process the data..

## 2. RESEARCH METHOD

In this study, so that the results obtained are precise and good, appropriate research methods are needed, and the research methods, Data collection techniques used by the author in collecting data for making. The author conducted direct observation activities at school libraries in the Bekasi area to obtain The author conducted interviews with the librarian. In this literature study method, the author conducts a heritage study review by studying theoretical books that can be used as a reference for designing a web-based library information system.in information and data related to the design of web-based library information systems.

The system development model used is the FAST (Framework for the Application System Thinking) method consisting of Scope Definition, Problem Analysis, Requirements Analysis, Logical Design and Physical Design phases (Sari & Nuari, 2017).

The discussion is explained according to the system development method used, namely the FAST (Framework for the Application System Thinking) method.

### a. Scope Definition

This stage is the first step in the process of designing an information system. This stage is the scope of the library information system in schools.

### b. Problem Analysis

Analysis of the existing problems is to library information system development

### c. Requirements Analysis

Analysis of the specified requirements, namely the needs for users and the needs of the system

### d. Logical Design

Design method that uses object-oriented design method using UML (Unified Modeling Language) as a design tool.

e. Physical Design

Is the stage of translating the logical design into the physical application. That is user interface design.

### 3. RESULTS AND DISCUSSIONS

The discussion is explained according to the system development method used, namely the FAST (Framework for the Application System Thinking) method.

a. Scope Definition

The scope of this library information system is, there are 2 pages, namely admin and members. Admin can manage book data, member data, borrowing and returning data up to reports. Meanwhile, members can register to become members, can borrow books, read books online

b. Problem Analysis

running in the school library still using manual methods, such as: a) The member registration process still uses the manual method, namely when inputting member data in the member's main book. b) The process of making a member card takes a long time because the officer must re-record the identity of the member on the membership card. c) Still having difficulty in searching for member data who will borrow and return books because they must first check the loan and return books. d) The process of making reports is still done manually so it takes a long time in the manufacturing process and the reports produced are less accurate.

Manual use in a system certainly has many shortcomings, including the information generated from manual data processing is less accurate due to possible errors that occur in the data recording process, manual data storage media usually use documents in the form of archived paper so that it requires more space. and in terms of security is not guaranteed.

c. Requirements Analysis

Identify the functional requirements of the program accompanied by the depiction of use case diagrams and use case scenarios related to the proposed library information system design process. User Needs In the application of web-based library information system design, there are two users who can interact with each other in the system environment, namely: librarian and librarian. Both users have interaction characteristics with different systems and have different information needs.

d. Logical Design

This stage is illustrated through use case diagrams and activity diagrams. Usecase or use case diagram is a modeling for the behavior (behavior) of the information system to be made. Use case describes an interaction between one or more actors and the information system that will be created. Roughly speaking, use cases are used to find out what functions are in an information system and who has the right to use those functions. (Sukamto & Salahudin, 2016).

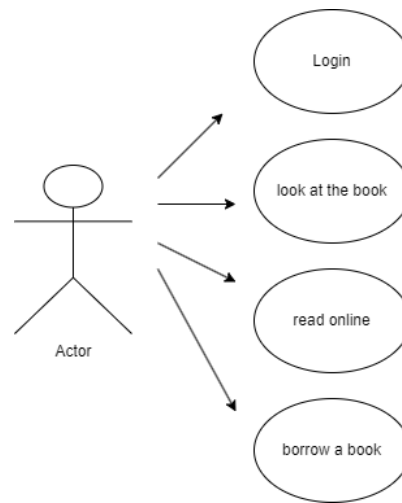

Figure 1. Use case diagrams

Use case diagrams for members. The use case illustrates that on this library website system members can login, view a list of books, read online and borrow books.

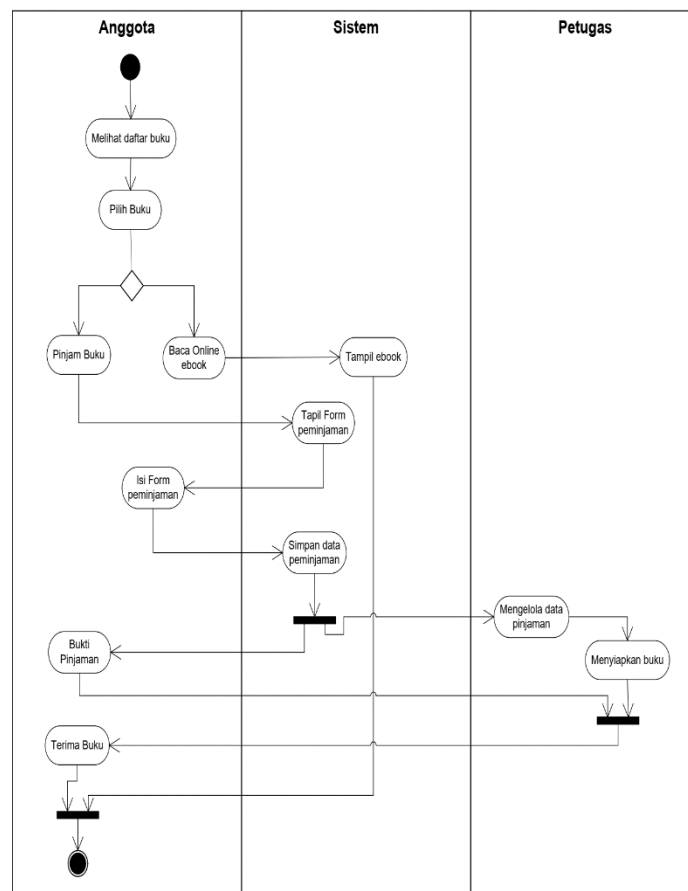
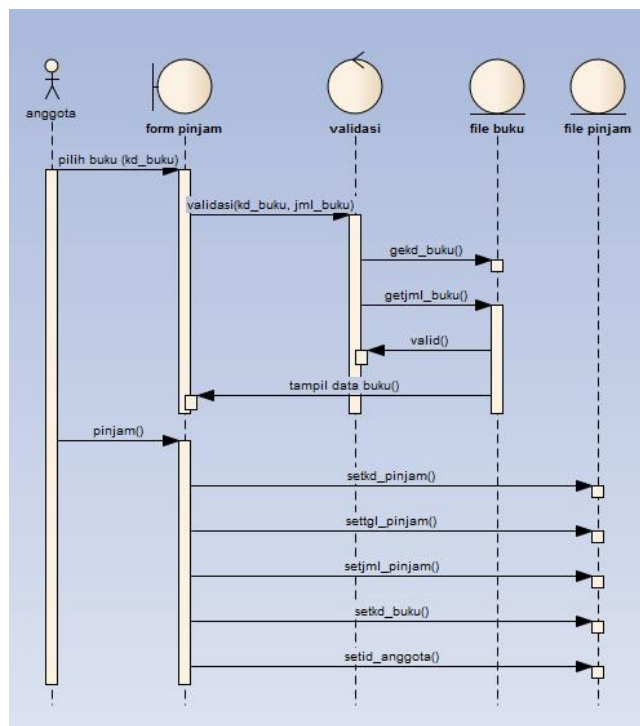

Figure 2. Activity Diagram

The activity diagram explains the flow of borrowing books in the library system. Starting from members viewing a list of books on the library web, then choosing a book, there are two options for



reading online and borrowing books. If you select read online, the system will display a book display on the screen. Meanwhile, if you choose to borrow books, the system will display a borrowing form, then members fill out the form. The system will process the data, for members will receive proof of borrowing and officers will receive loan data. To take the book, members must submit proof of loan and the officer will hand over the borrowed book.

Figure 3. Sequence Diagram

In the sequence diagram above, the flow is: Members select a book and fill out a loan form. The system will validate the book code data and the number of books based on the book file. If the data match, the system will display it on the loan form. Members make loans and the data in the loan form will be stored on the loan file.

#### e. Logical Design

The following is the design of the Logical Record Structure (LRS) used.

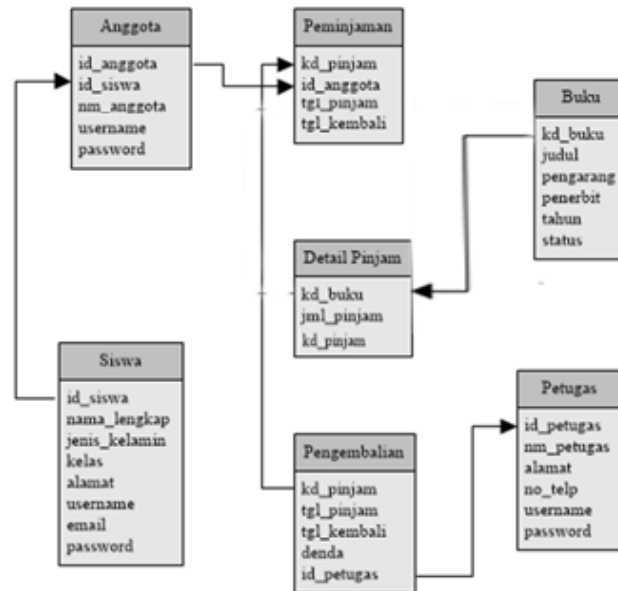

Figure 4. Logical Record Structure (LRS)

The picture above is a representation of the structure of the records in the tables formed from the results between sets of entities. There are seven entities and their related records.

Login Page, This page serves as login access for the library website.



Figure 5. Login Page

This page is the main gateway to the library website. On the login page, the user must first enter a username and password to enter the library website system.

Borrowing Page, This page is used by members to borrow books. With the condition that members must log in first.

Figure 6. Loan Page

The borrowing page is a form that members must input if they want to borrow a book. And proof of borrowing can be printed to be handed over to the officer to pick up the borrowed book.

#### 4. CONCLUSION

Based on the research conducted, it can be concluded that the library information system website makes it easier for students in the process of borrowing books, students can find out what books are available in the library, make it easier for admin or library officers to manage library data, such as book data, member data, borrowing and return of books, and provide convenience in the service process for its users.

#### REFERENCES

- Masithoh, R. F., Jisarah, A. C., Annisa, L. N., Iqbal, M., Khakim, M., Ghani, F. A., & Fajrin, P. A. (2021). Efforts to improve 3R literacy (reduce, reuse and recycle) in creating a healthy environment. *Community Empowerment*, 6(12), 2158-2163.
- Iqbal, M., Siahaan, A. P. U., Purba, N. E., & Purwanto, D. (2017). Prim's Algorithm for Optimizing Fiber Optic Trajectory Planning. *Int. J. Sci. Res. Sci. Technol*, 3(6), 504-509.
- Iqbal, M., & Permadi, M. R. (2021, March). Analysis of integration dietducate and automated meal planner for nutritional purposes. In *IOP Conference Series: Earth and Environmental Science* (Vol. 672, No. 1, p. 012079). IOP Publishing.
- Sari, S. N. (2022). PEMANFAATAN KERANGKA KERJA INVESTIGASI FORENSIK JARINGAN UNTUK IDENTIFIKASI SERANGAN JARINGAN MENGGUNAKAN SISTEM DETEKSI INTRUSI (IDS). *Jurnal Nasional Teknologi Komputer*, 2(3), 150-158.
- Sari, S. N., Kaban, R., Khaliq, A., & Andari, A. (2022). Sistem Penjadwalan Mata Pelajaran Sekolah Menggunakan Metode Hybrid Artificial Bee Colony (HABC). *Jurnal Nasional Teknologi Komputer*, 2(1), 20-32.
- Rahmanto, Y., & Hotijah, S. (2020). Perancangan Sistem Informasi Geografis Kebudayaan Lampung Berbasis Mobile. *Jurnal Data Mining Dan Sistem Informasi*, 1(1), 19-25.
- Damayanti, D., Sulistiani, H., & Umpu, E. F. G. S. (2021). Analisis dan Perancangan Sistem Informasi Akuntansi Pengelolaan Tabungan Siswa pada SD Ar-Raudah Bandarlampung. *Jurnal Teknologi Dan Informasi*, 11(1), 40-50.
- Riswanda, D., & Priandika, A. T. (2021). Analisis Dan Perancangan Sistem Informasi Manajemen Pemesanan Barang Berbasis Online. *Jurnal Informatika Dan Rekayasa Perangkat Lunak*, 2(1), 94-101.
- Sallaby, A. F., & Kanedi, I. (2020). Perancangan Sistem Informasi Jadwal Dokter Menggunakan Framework Codeigniter. *Jurnal Media Infotama*, 16(1).

Bagir, H., & Putro, B. E. (2018). Analisis Perancangan Sistem Informasi Pergudangan di CV. Karya Nugraha. *Jurnal Media Teknik Dan Sistem Industri*, 2(1), 30-38.