



# Implementation Of The Dude Application As A Network Management System

Wahyudi manik<sup>1</sup>, Fahmi Kurniawam<sup>2</sup>,

<sup>1,3</sup>Computer System Department of Universitas Pembangunan Panca Budi Medan Indonesia

---

---

## Article Info

### Article history:

Received Sep 19, 2023

Revised Sep 20, 2023

Accepted Sep 22, 2023

---

### Keywords:

Computer Networking

Monitoring

The Dude

---

---

## ABSTRACT

The development of information technology and especially networks is very rapid. Therefore, there is a demand for a sophisticated computer network system. Where the admin cannot know the condition of each user's computer and whether the existing service system is on or off. Display and sound are technologies for detecting network damage on company computers. Implementation of a computer network client monitoring system using display and sound allows the system to send reports when a client computer or service shuts down automatically to the admin without involving the user. For this reason, researchers are trying to develop The Dudemonitoring network application in the form of display and sound. The results obtained from using this network monitoring application are monitoring the services carried out by each host or IP address. If a network error is correctly detected, a notification will be sent to the network administrator, then the network administrator will be able to repair network damage..

*This is an open access article under the [CC BY-NC](https://creativecommons.org/licenses/by-nc/4.0/) license.*



---

---

## Corresponding Author:

Wahyudi Manik,

<sup>3</sup>Computer System Department of Universitas Pembangunan Panca Budi Medan Indonesia.

Email:

---

---

## 1. INTRODUCTION

The rapid development of technology has had a major impact on every aspect of human life. One of them is the development of the internet. The rapid development of the internet has helped the effectiveness and efficiency of a company's operations. Increasing the operational quality of a company will make the company produce good and large production. Operational performance in a company is supported by various types of devices that are connected to each other using various systems and applications that are connected by internet network devices.

Maintaining devices and transmission cycles on the network requires a solution that can monitor the occurrence of disturbances at any given time, by maintaining the network as soon as possible the necessary treatment can be carried out, thus making a company's operations always stable. Therefore, there is a need for network management and monitoring to monitor the traffic cycle on the network.

Analysis and implementation of network traffic monitoring cycles is needed to improve the quality of network services such as in a

detection of anomalies in network performance. The problem in analyzing and monitoring network traffic today is maintaining network stability and dealing with the very large increase in the amount of data generated by interconnected network links as well as analyzing network data generated from various applications such as streaming media, peer to peer and applications. games. One of the network problems that often occurs is damage to network elements such as hubs, bridges, routers and so on, where the error is not known by network users manually and checking the network takes too long.

Computer network monitoring is the main method for maintaining computer network stability. With monitoring, it is hoped that if a problem occurs on the network it can be repaired quickly and easily. The most common network monitoring is monitoring the amount of bandwidth usage.

The Dude application is an easy alternative for monitoring. The Mikrotik network company created an application called The Dude with the aim that this application can carry out management on a network. The dude will automatically read or detect every device connected to the same network segment. Apart from that, it can also compile network topology plans, and can carry out monitoring and provide messages if there are problems with devices connected to the network.

Client/Server is a network architecture that separates the client from the server. Each client can request data or information from the server.

Client/server systems are defined as distributed systems, but there are several differences in characteristics, namely:

1. Service (service)
  - a) Relationship between processes running on different machines.
  - b) Separation of functions based on service ideas.
  - c) Server as provider, client as consumer.
2. Sharing resources (resources)

The server can serve several clients at the same time, and regulates joint access to share resources to ensure consistency.

3. Asymmetrical protocol (a protocol that is not symmetrical)

Many-to-one relationship between client and server. Clients

always initiates the dialog via the request service, and the server waits passively for requests from the client.

4. Location transparency

The process carried out by the server may be located on the same machine or on a different machine via the network. The server location must be easy to access from the client.

5. Communication-based messages

Server and client interaction through sending messages that include requests and answers

6. Separation of interface and implementation

The server can be upgraded without affecting the client as long as the published message interface does not change.

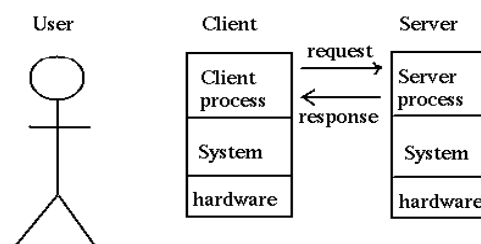

Figure. 1. Client/Server System

## 2. RESEARCH METHOD

### 2.1 Winsock

Windows Sockets (Winsock) is a network programming interface for Microsoft Windows that is based on the popular "sockets" on BSD Unix. Winsock includes both Berkeley and Windows models. The Winsock 1 application can ask Winsock to send notifications in the message window. This allows the program to handle network, UI issues, background processes simultaneously. Winsock 2 adds many features. Winsock has 2 (two) interfaces, namely, the Application Programming Interface (API) which protects application developers from the lower layers and the Service Provider Interface (SPI) which allows expansion of Winsock. By using the API, Winsock applications can work with various network transport protocols and Winsock implementations.

Winsock is often found in game applications and databases that are built using the Visual Basic programming language and are connected and exchange data using the TCP/IP protocol.

Explaining research chronological, including research design, research procedure (in the form of algorithms, Pseudocode or other), how to test and data acquisition [1-3]. The description of the course of research should be supported references, so the explanation can be accepted scientifically [2, 4].

Tables and Figures are presented center, as shown in Table 1 and Figure 1, and cited in the manuscript before appeared.

### 2.2 Winscock and TCP/IP

The network consists of several layers. When network people talk about these layers, they usually refer to the OSI model. TCP/IP is a network protocol that is at layers 3 and 4. The network protocol provides services such as addressing, data transport, routing, and logical connections over a network of 2 (two) computers that must use the same network protocol so that programs on the computers can communicate. . TCP/IP is the most popular network protocol today because all computers support it. Winsock is an API that allows Windows programs to send data via any network communication protocol. There are some Winsock functions that only work with TCP/IP, but there are newer generic versions of all the functions in Winsock 2 that allow using other transports.

### 2.3. The Dude

The Dude is a free application from Mikrotik that can be used to monitor and manage the path of a network device (Tabona, 2013). The Dude is currently divided into 2 versions, namely The Dude Server which is installed on the Router while The Dude Client which is used on the Client Laptop. Currently, The Dude Server only supports several Mikrotik devices such as Tile, ARM, MMIPS, x86 and CHR. The Dude is known as a complete application. Apart from being able to monitor the network in the form of a map, notification of changes in device status, there are also tools such as SSH, Telnet, Webfig which can provide direct remote access to the device.

The dude will also automatically read or detect every device connected to the same network segment. Apart from that, it can also compile a network topology design, and can carry out monitoring and provide information if there are problems with devices connected to the network (Sutarti, 2017).

Until now, The Dude is widely used by users to manage their networks. Several reasons why this application is in great demand are (Adi Widodo, 2015):

1. The Dude is a non-paid application (FREE)
2. Installation and use are quite easy.
3. Can perform discovery & layout of various types/brands of devices automatically.
4. Can do remote directly to manage the device.
5. Supports SNMP, ICMP, DNS and TCP monitoring
6. Can run on Windows OS, Linux (Wine) and MacOS (Darwine).

After analyzing the data from existing problems, the device

Free and open source software is the most appropriate solution to solve the problems that occur in this company. Many open sources are free and can also be modified without any moral burden on the issue of piracy. Even though its use is difficult for some groups, this is the best solution if a company does not want to pay a high price for providing this infrastructure.

This software also runs on a very simple operating system, namely Microsoft Windows. With this, companies can reduce costs quite significantly compared to having to pay for a paid system, not to mention maintenance costs. However, the new problem is finding open source software with the right and efficient features according to the company's needs. After the review process of existing problems, it can be concluded that the monitoring system needed by the company is:

- Low Cost, High Scalability, Buildable, Real Time Operation and High Extensibility.
- SLA Reports (Bandwidth down and Availability), Reporting with Alarms, and Status Display.
- Assist in the analysis, troubleshooting and reporting processes.
- Able to display network performance information both in graphic and display form.
- Very Easy to use.
- Better visualization.

After conducting a direct comparison with the software usage trial process using an iterative approach, it was concluded that "The Dude" could be a solution for the company. The Dude Network Monitor is a new application from Mikrotik which can be a way to manage the company's network environment, The Dude will automatically quickly read all devices/computers connected to the network in one local network, drawing from the map design of the company's local network, observe the service of the device or computer and notify if there are service problems with the device/computer in the company's local network.

#### 2.4. Design Networking System

To discuss the design of a computer network that will be monitored, you need a flow diagram to make it easier to understand the stages of problem solving

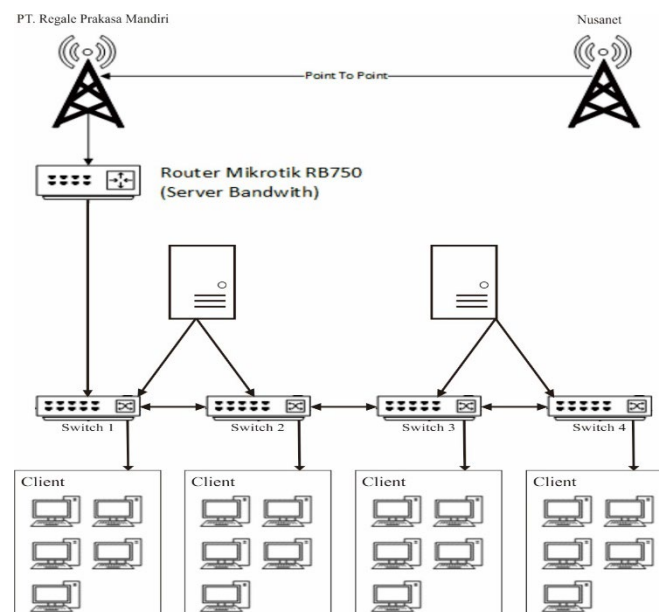

Figure 2. Networking Topology

### 3. RESULTS AND DISCUSSIONS (10 PT)

The initial display on The Dude has a "Server" column which displays the IP Address of the Router that is connected to The Dude Server, then there is a radiobutton for selecting "Mode" which has two modes, namely "plain mode for basic display" and "secure mode for security advanced level", there is also a "Port" column whose normal port is 2210, there are "Username" and "Password" columns, namely the Router username and password and there is a "button connect" to enter the appearance of The dude Client

#### 3.1. Initial appearance of The Dude

The initial display on The Dude Client contains various menus that will be used as tools to design a network, but if you are connected to a router then just search for the network in the following way:

- a. Do Discovery by clicking the Local menu on the content tool, then the submenu above, click the Discovery button.
- b. In the Discovery display, select the IP Address that is already connected.
- c. After the discovered network appears, then carry out maintenance on the network.

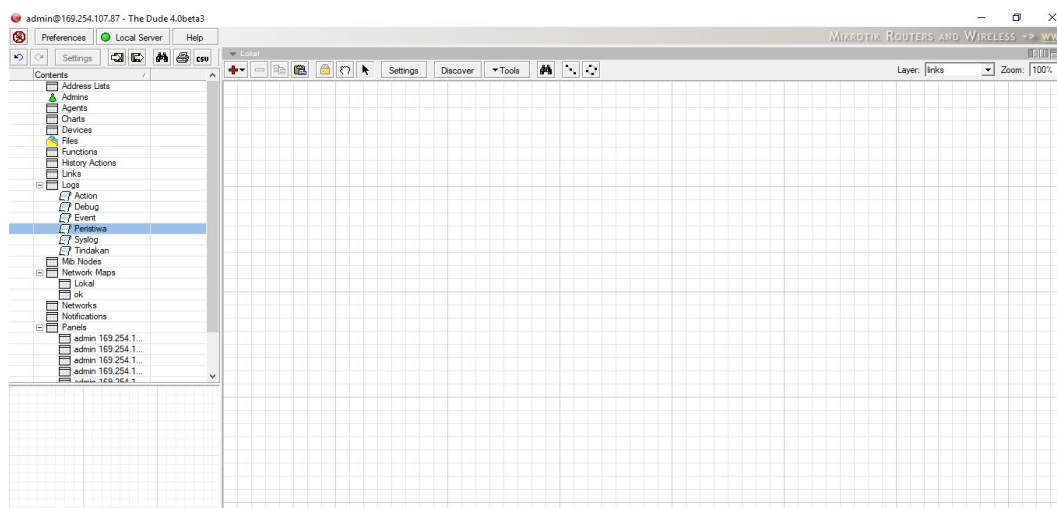

Figure 4. Initial appearance of The Dude

#### 3.2. Implementation The Dude

Testing is the process of executing an implementation that has been carried out to assess and determine errors contained in the system. With testing, it is hoped that the system will have good quality and can be used as reference material in the further system development process.

Testing was carried out to monitor the network using The Dude application. Requires two The Dude applications, namely the Dude server application and The Dude client application.

- 1) Install the Dude server application into the router, using Winbox and the version must be the same, here using Router RB4011, Winbox version 3.20, The Dude Server 6.43.npk and The Dude Client 6.43, as shown in the following picture:

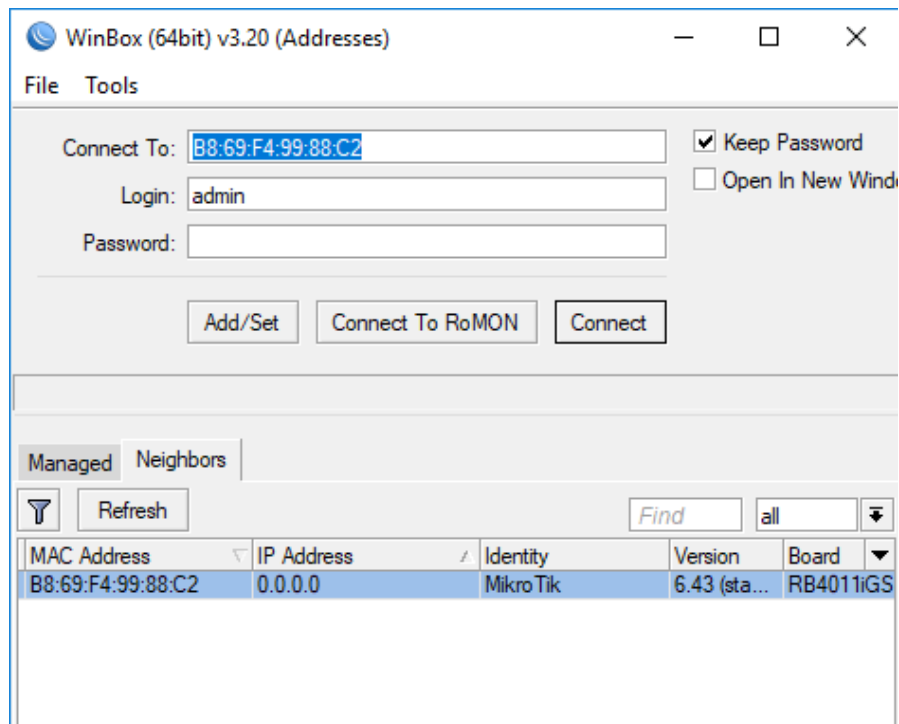

Figure 5. winbox display

After entering Winbox, update The Dude Server to the "FILES" menu, as shown in the image below:

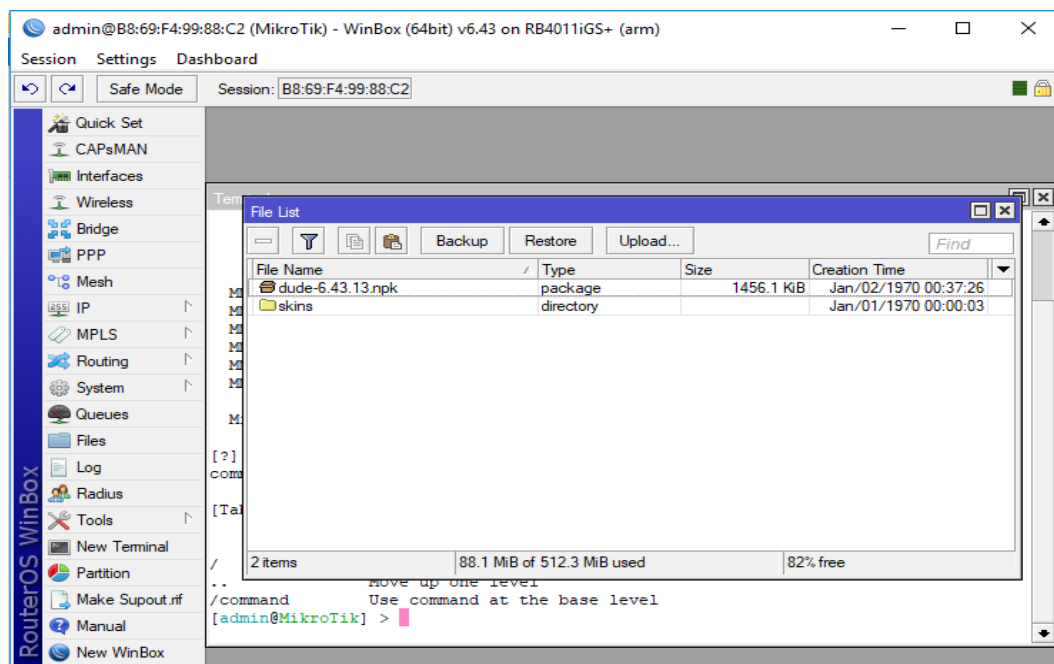

Figure 6. The Dude server ini winbox

#### 4. CONCLUSION (10 PT)

After that, enable dude and SNMP on Winbox, so monitoring can be done using The Dude Client which will later be installed on the client, and shown ;

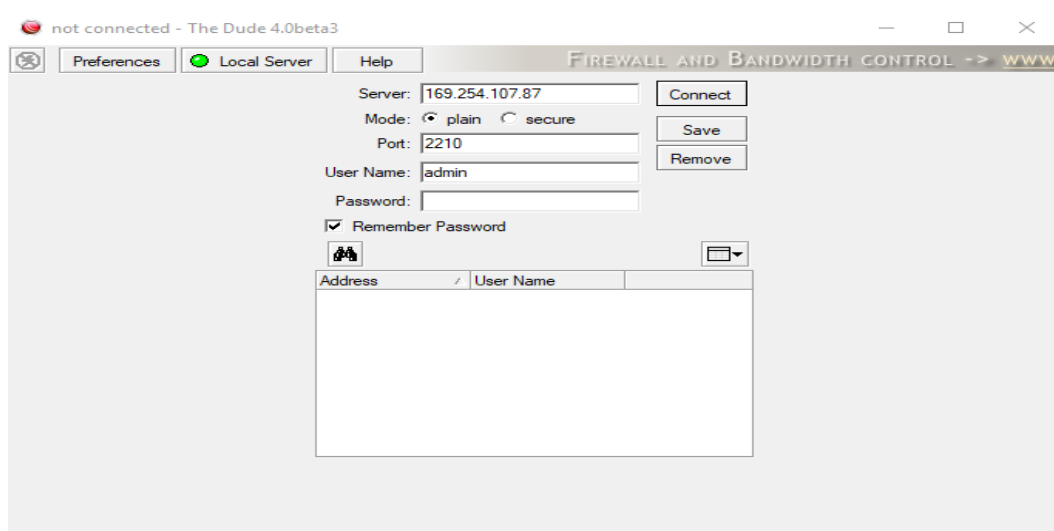

Figure 7. The Dude Client

On the client, you must fill in the column based on the IP connected to the server, the server IP is 169.254.107.87, select plain username and password mode according to the router then click the Connect button and the display will change to the following ;

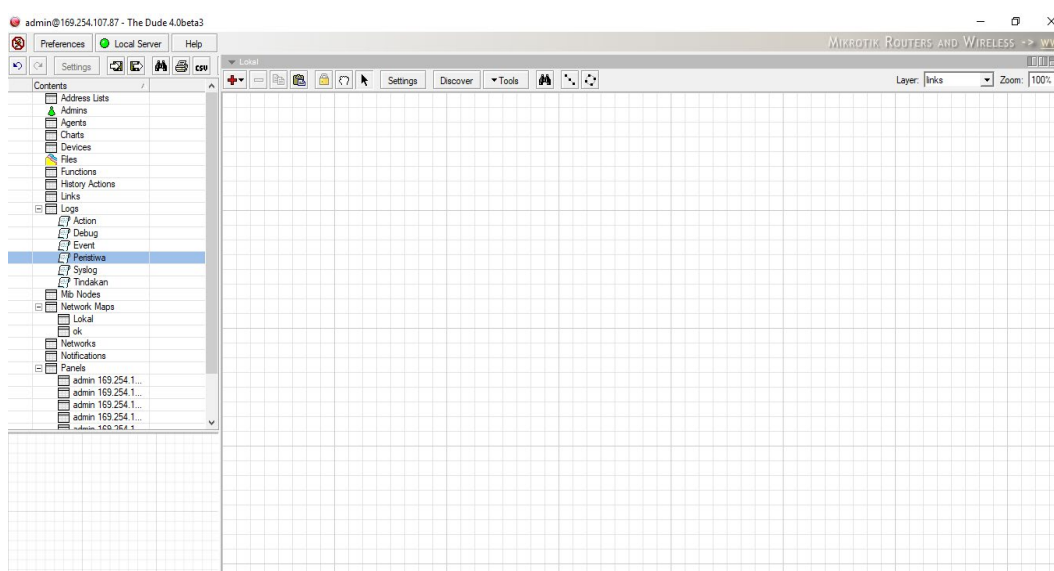

Figure 8. The Dude in Client

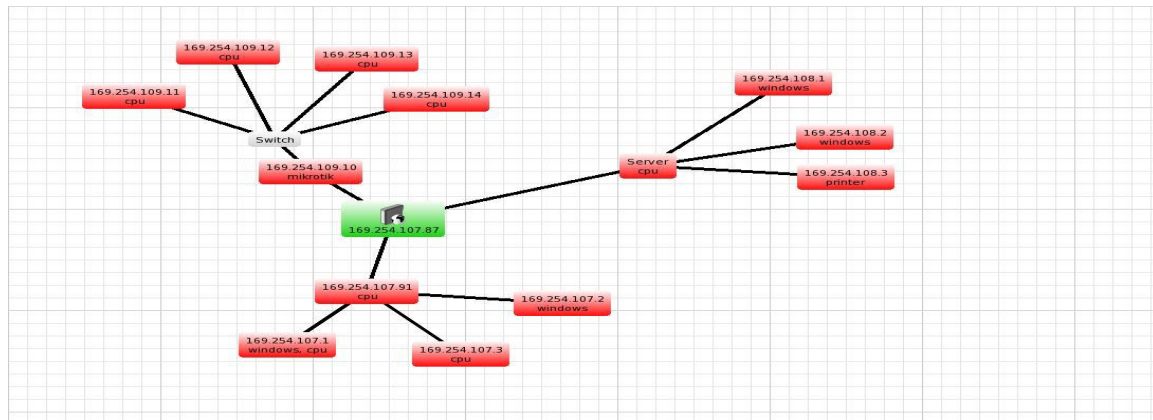

Figure o. The Result Display Dude in Client

## REFERENCES

- Ginta, P. W., Kusuma, G. P., & Negara, E. K. (2013). Implementation of Network Mapper Tools on Local Area Network (LAN). *Infotama Media Journal*, 9.
- Goeritno. (2015). Analysis and Implementation of an Internet Data Packet Traffic Monitoring System Using Cacti, Jffnms and The Dude. Scientific Publications.
- Idrus, A. (2016). PT Network Monitoring System. Exhibition Network Indonesia with THE Dude Based on Mikrotik. *Informatics for Educators and Professionals*, 1.
- Rinaldo, R. (2016). Implementation of a Network Monitoring System Using Mikrotik Router OS at Batik Islamic University, Surakarta, 16.
- Sutarti, & Alfiansyah, A. (2017). Analysis and Implementation of an Internet Connection Monitoring System Using The Dude at STIKOM Al-Khairiyah.
- Tjiptadi, R. (2014). VPN Based Network System Using REMOTE-ACCESS Method. *Fifo*, VI(2).
- Wibisono, Faizin Wahid. (2013). "Analysis and Implementation of Access Points at PT. SELARAS CITRA TERABIT Using The Dude Software". Thesis. High School.
- Khaliq, A., Arianti, C., Simanjuntak, C. A., & Harahap, D. A. P. (2023). Perancangan Website Profil Program Studi Menggunakan Content Management System Wordpress. *Jurnal Nasional Teknologi Komputer*, 3(3).
- Khaliq, A., Batubara, S., Syaula, M., & Lubis, Y. E. (2022). Perancangan Sistem Karir Berbasis Web Menggunakan Framework Laravel. *Brahmana: Jurnal Penerapan Kecerdasan Buatan*, 4(1A), 28-34.
- COVIDSurg Collaborative, GlobalSurg Collaborative, Nepogodiev, D., Simoes, J. F., Li, E., Picciochi, M., ... & Pellino, G. (2021). Effects of pre-operative isolation on postoperative pulmonary complications after elective surgery: an international prospective cohort study. *Anaesthesia*, 76(11), 1454-1464.
- Zhang, Y. Y., Zhang, Y. M., Wu, S. L., Wei, M., Deng, Z. P., Lei, X. Y., ... & Wang, X. B. (2023). Association of mechanical power during one-lung ventilation and post-operative pulmonary complications among patients undergoing lobectomy: a protocol for a prospective cohort study. *Updates in Surgery*, 1-11.
- Cavayas, Y. A., Eljaiek, R., Rodrigue, É., Lamarche, Y., Girard, M., Wang, H. T., ... & Denault, A. Y. (2019). Preoperative diaphragm function is associated with postoperative pulmonary complications after cardiac surgery. *Critical care medicine*, 47(12), e966-e974.